



# AXELENT STORE

Mesh wall systems for warehouses,  
industry and storerooms





## WE KNOW ALMOST EVERYTHING THERE IS TO KNOW ABOUT SAFETY AND **MESH WALL SYSTEMS**

Axelent is a Swedish company with extensive experience within the manufacture of mesh wall systems in the form of protection and partitioning systems for industry, warehouses and construction work. Speed, safety and service are watchwords that characterise our entire organisation and business.

### **Effective production**

Our head office is in Hillerstorp, Sweden. All product development, production, warehousing and packaging also takes place here.

Much of our production is automated in order to cope with high volumes and fast delivery times. All our standard products are held in stock, we work on a standard 5 – 7 day lead time.

### **Quotation and drawing straight away**

Our own SnapperWorks drawing application enables us to quickly provide you with a quotation including a drawing and material specification.

### **Axelent deliveries**

Thanks to Axelent's in-house packaging system, X-pack™, your Axelent products are delivered on specially adapted pallets, attractively and neatly wrapped in plastic, complete with assembly instructions.

This means that products can be assembled quickly and easily making the goods easy to unload and move. We also offer technical assistance where needed.

### **A safe choice**

Axelent has extensive, in-depth knowledge when it comes to safety for industry, warehouses and construction work. Please consult us in order to get as safe and secure an environment as possible using our products.





**Safe.** Axelent's warehouse partitioning systems are developed and manufactured to satisfy all the requirements that are today placed on practical warehouse partitioning systems. Excellent safety characteristics in the different systems are naturally a matter of course. As such, our mesh wall systems fulfill the EN standard that apply to this category of protection.

**Practical.** Besides safety it is important that your mesh wall system also functions as smoothly as possible. The idea behind our Store system is that it should facilitate all work that takes place both inside and outside the mesh walls. For maximum function we recommend that you also take a look at our range of accessories.

**Versatile.** Axelent's warehouse partitioning systems are built standardised as modular panels, posts and colours. This ensures that you can seamlessly complement existing protection as is required. You will also discover how easy it is to assemble our products. Not least thanks to our user friendly assembly instructions.

**Economical.** Smooth and easy handling, together with speed of delivery and assembly ensure that you always obtain a good total economy when you choose Axelent's warehouse partitioning systems.

#### **Four different systems**

Axelent's warehouse partitioning systems are divided into four complete systems that are all known as Store systems: **SafeStore**, **FlexiStore**, **ShelfStore** and **StoreRoom**.

Which one you choose depends on your particular requirements. We are very willing to guide you in your selection.

We ensure that all our standard-colour warehouse partitioning systems are kept in stock.



**More information and news on the Internet!**  
On our Internet site [www.axelent.com](http://www.axelent.com) you can read more about us, our products, news and accessories. Welcome!

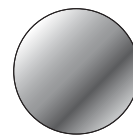
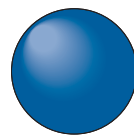
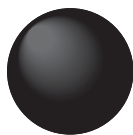
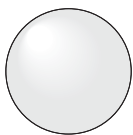
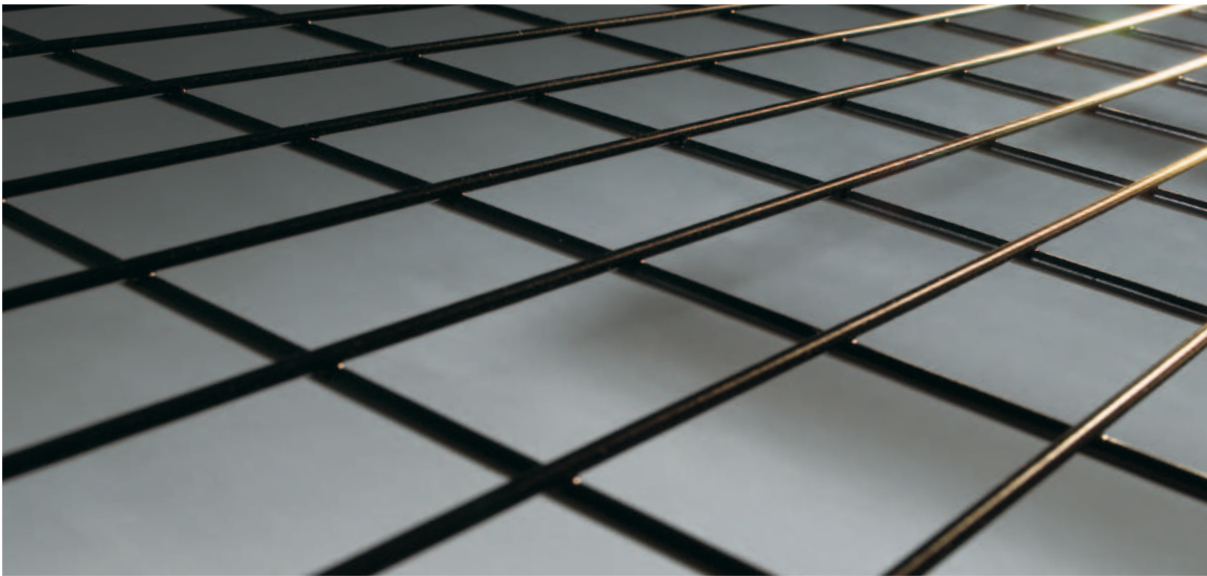

# SAFESTORE ANTI-COLLAPSE PROTECTION SYSTEM



The Axelent SafeStore anti-collapse protection system is supplied with special brackets in customer-specific colours to match the rest of the customer's facility.



Axelent SafeStore with 50x60 mesh spacing. Project delivered to Scania in Oskarshamn.

**Axelent SafeStore** is the ultimate solution for a safe, tidy and easy-to-use warehouse. When SafeStore is fitted to the rear of a pallet rack it prevents goods from falling out and causing injury to personnel or damage to goods. Today SafeStore is used in all types of situations, from small manually operated warehouses to the fully automated crane operations.

The SafeStore system is based around six standard panels that can be adapted to suit practically all modern racking systems. The panels are attached to the racking uprights using brackets and then bolted together to give the desired width and height. A choice of three mesh sizes lets you combine safety with economy. You can also cut the mesh panels to achieve an optimal fit. Everything is supplied wrapped on specially adapted pallets direct from our warehouse in Hillerstorp, Sweden.

## PRODUCT FACTS

Uprights	15 x 15 mm
Horizontals	19 x 19 mm
Vertical wires	Ø 2.5 mm
Horizontal wires	Ø 3 mm
Mesh aperture	cc 25 x 25, 51 x 31 mm, 51 x 60 mm
Brackets	Made from 3 mm sheet metal. With elongated holes to allow vertical adjustment.
Finish	Phosphatizing/Epoxy paint
Colour mesh panel	Light grey RAL 9018 Black RAL 9011 (only 30 x 50 mm)
Colour bracket	Light grey RAL 9018 Silver RAL 9006 Sendzimir galvanized (other colours can be quoted)



**More information and news on the Internet!**  
On our Internet site [www.axelent.com](http://www.axelent.com) you can read more about us, our products, news and accessories. Welcome!

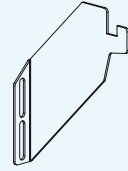
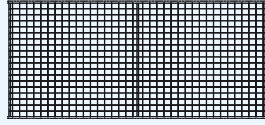
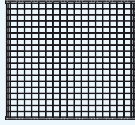

MESH PANELS (Mesh 25x25 mm)		
Art.no.	Height (mm)	Width (mm)
<b>Light grey (RAL 9018)</b>		
406-100-110	1000	1100
406-120-110	1200	1100
406-150-110	1500	1100
406-100-220	1000	2200
406-120-220	1200	2200
406-150-220	1500	2200

MESH PANELS (Mesh 50x30 mm)		
Art.no.	Height (mm)	Width (mm)
<b>Black (RAL 9011)</b>		
301-100-110	1000	1100
301-120-110	1200	1100
301-150-110	1500	1100
301-100-220	1000	2200
301-120-220	1200	2200
301-150-220	1500	2200

MESH PANELS (Mesh 50x60 mm)		
Art.no.	Height (mm)	Width (mm)
<b>Light Grey (RAL 9018)</b>		
402-100-110	1000	1100
402-120-110	1200	1100
402-150-110	1500	1100
402-100-220	1000	2200
402-120-220	1200	2200
402-150-220	1500	2200

BRACKETS	
Art.no.	Length (mm)
<b>Brackets Light grey (RAL 9018)</b>	
430-050-000	50
430-100-000	100
430-125-000	125
430-150-000	150
430-175-000	175
430-200-000	200
430-250-000	250
430-300-000	300

Brackets (Senzimir galvanized)	
25-8003	0
630-050-000	50
630-100-000	100
630-125-000	125
630-150-000	150
630-175-000	175
630-200-000	200

Brackets Silver (RAL 9006)	
630-250-000	250
630-300-000	300



① Axelent's anti-collapse is easy to assemble. The mesh panels are bolted together vertically. Joining clamps are used at the top edge of the top row and the bottom edge of the bottom row.

② Upright extensions are available as an accessory. This makes it possible to install mesh panels up to 1500mm above the standard upright.

③ The brackets are available in nine different increments, from 0- 300 mm, painted or galvanized.



# FLEXISTORE WAREHOUSE PARTITIONING SYSTEM



## PRODUCT FACTS

Uprights	30 x 20 mm
Horizontals	25 x 15 mm
Posts	70 x 25 mm or 50 x 50 mm
Vertical wires	Ø 3 mm
Horizontal wires	Ø 2.5 mm
Mesh aperture	cc 51 x 60 mm
Finish	Phosphatizing/Epoxy paint
Colour mesh panels	Light grey RAL 9018
Colour post	Silver RAL 9006
Colour U-section	Light grey RAL 9018 (other colours can be quoted)

◀ Here FlexiStore functions as a partition for a section of the IKEA department store in Leeds, UK.

Divide off or enclose. Build new, modify or expand. The needs can differ in your industry or in your warehouse. However if you choose Axelent FlexiStore you can rest assured. This warehouse partitioning system offers almost unlimited potential in the way the various elements can be combined and used. At the same time you gain a versatile, safe and economical system, characteristics that apply to all Axelent products.

The FlexiStore panels are available in various heights and numerous widths depending on mesh aperture. Using feet, uprights and extensions, you can then adapt your warehouse partitioning system to suit your particular needs. If you require a special solution then we can also offer a cutting service to tailor your industrial or storeroom mesh walls to fit precise horizontal or vertical dimensions.

**Axelent offers an endless variety of combinations and solutions with FlexiStore – the most versatile system for industrial and storeroom enclosure.**

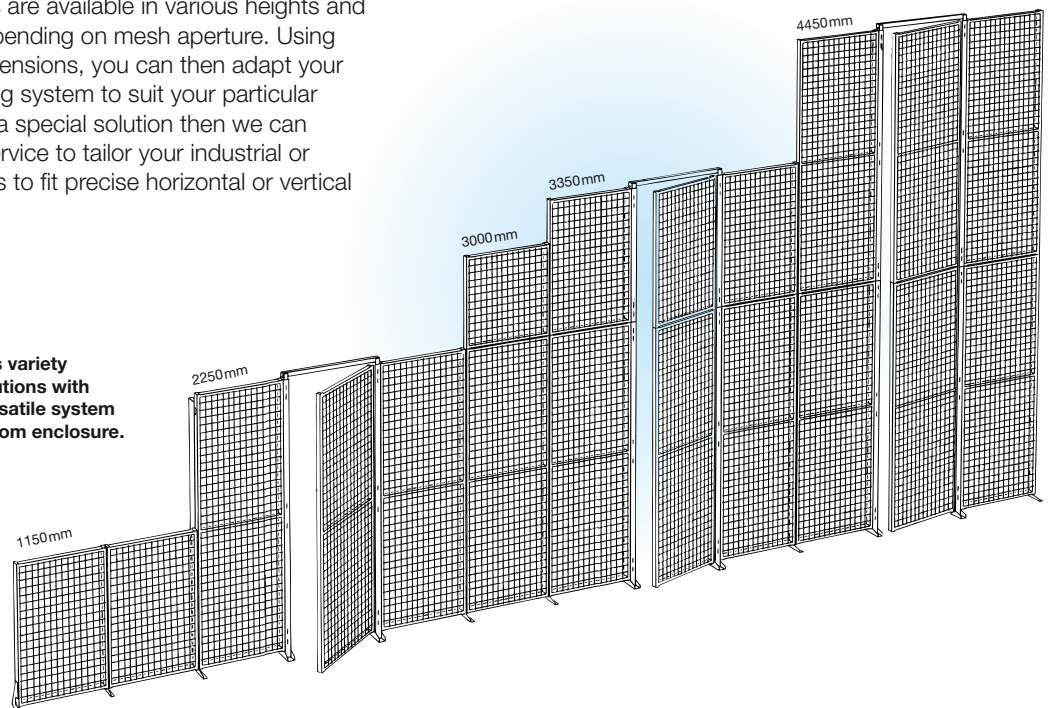

You can also combine FlexiStore with any of our door packages. If you want a special colour adapted to other fittings, we can of course arrange this. However in this case, the same delivery time as for our standard colours is not applicable. Naturally, we supply everything on specially adapted pallets direct from our own warehouse in Hillerstorp, Sweden.

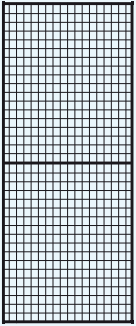

### MESH PANELS (Height 2200 mm)

Art.no.	Height (mm)	Width (mm)
<b>Light grey (RAL 9018)</b>		
404-220-025	2200	250
404-220-040	2200	400
404-220-070	2200	700
404-220-100	2200	1000
404-220-120	2200	1200
404-220-150	2200	1500

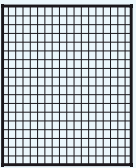

### MESH PANELS (Height 1100 mm)

Art.no.	Height (mm)	Width (mm)
<b>Light grey (RAL 9018)</b>		
404-110-025	1100	250
404-110-040	1100	400
404-110-070	1100	700
404-110-100	1100	1000
404-110-120	1100	1200
404-110-150	1100	1500

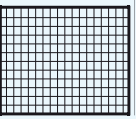

### MESH PANELS (Height 750 mm)

Art.no.	Height (mm)	Width (mm)
<b>Light grey (RAL 9018)</b>		
404-075-025	750	250
404-075-040	750	400
404-075-070	750	700
404-075-100	750	1000
404-075-120	750	1200
404-075-150	750	1500

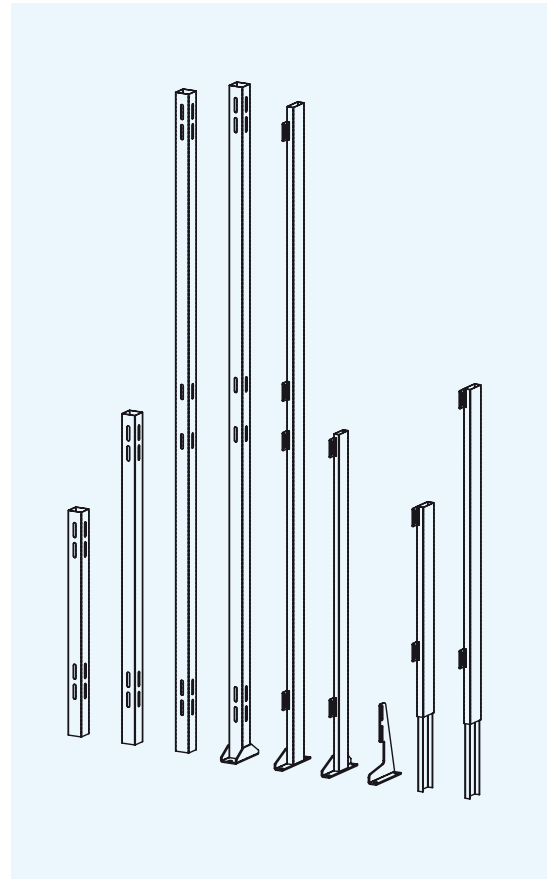

### POSTS

Art.no.	Gap to floor (mm)	Height (mm)
---------	-------------------	-------------

#### Silver (RAL 9006)

##### Foot

693-030-000	50	300
-------------	----	-----

##### Post (70x25 mm)

692-225-000	50	2250
692-115-000	50	1150

##### Post extension (70x25 mm)

692-110-000		1100
692-075-000		750

##### Door post (50x50 mm)

690-225-005	50	2250
-------------	----	------

##### Post extension (50x50 mm)

690-220-005		2200
690-110-005		1100
690-075-005		750



◀ Axellent FlexiStore, 4.45 m in height with 50x60 mesh spacing. Image from Mory, France.



# FLEXISTORE PLASTIC AND SHEET METAL PARTITIONING SYSTEMS



## PRODUCT FACTS

Uprights	30 x 20 mm
Horizontals	25 x 15 mm
Plastic	2 mm (thermoplastic polyester)
Sheet metal	0,8 mm
Posts	50 x 50 mm
Colour panel	Black RAL 9011 Light grey RAL 9018
Colour post	Blue RAL 5005 Silver RAL 9006 Black RAL 9011 Yellow RAL 1018 Light grey RAL 9018 (other colours can be quoted)

◀ Axelent FlexiStore plastic and sheet metal wall system at the Renault Cléon plant in France.

Axelent's plastic and sheet metal system also belongs to the FlexiStore group of products. The versatility of our systems means that you can combine plastic, sheet metal and mesh according to your particular requirements. To avoid gaps between the different panels, we recommend that you use our specially adapted sheet metal strip, see page 9 for more information. A system that is easy to assemble and which gives you the possibility to use the same posts and door packages as for our other mesh wall products.

The plastic and sheet metal panels are available in two heights: 1100 and 2200 mm, as well as in four standard widths.

Axelent's FlexiStore plastic and sheet metal systems ideally suit warehouses that require versatile view protection or, for example, around an aerosol warehouse. Everything is delivered carefully wrapped on specially adapted pallets direct from our own warehouse in Hillerstorp, Sweden.

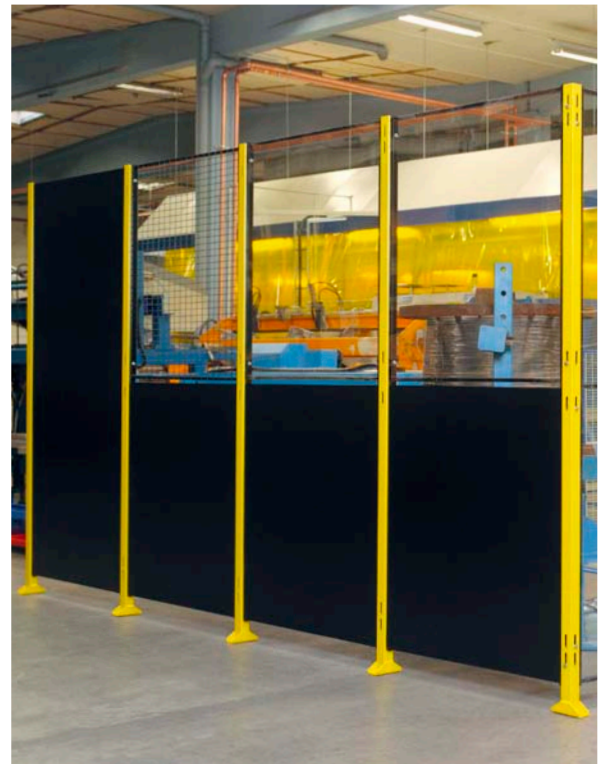

**More information and news on the Internet!**  
On our Internet site [www.axelent.com](http://www.axelent.com) you can read more about us, our products, news and accessories. Welcome!





#### WALL PANELS PLASTIC (Height 2200 mm)

Art.no.	Height (mm)	Width (mm)
<b>Light grey (RAL 9018)</b>		
410-220-025	2200	250
410-220-040	2200	400
410-220-070	2200	700
410-220-100	2200	1000



#### WALL PANELS PLASTIC (Height 1100 mm)

Art.no.	Height (mm)	Width (mm)
<b>Light grey (RAL 9018)</b>		
410-110-025	1100	250
410-110-040	1100	400
410-110-070	1100	700
410-110-100	1100	1000

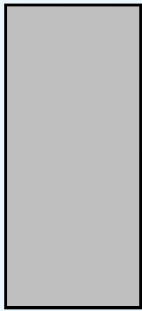

#### WALL PANELS SHEET METAL (Height 2200 mm)

Art.no.	Height (mm)	Width (mm)
<b>Light grey (RAL 9018)</b>		
411-220-025	2200	250
411-220-040	2200	400
411-220-070	2200	700
411-220-100	2200	1000

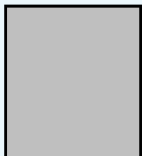

#### WALL PANELS SHEET METAL (Height 1100 mm)

Art.no.	Height (mm)	Width (mm)
<b>Light grey (RAL 9018)</b>		
411-110-025	1100	250
411-110-040	1100	400
411-110-070	1100	700
411-110-100	1100	1000

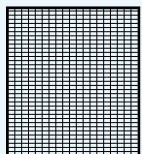

#### MESH PANELS (Height 1100 mm)

Art.no.	Height (mm)	Width (mm)
<b>Light grey (RAL 9018)</b>		
412-110-025	1100	250
412-110-040	1100	400
412-110-070	1100	700
412-110-100	1100	1000

#### POSTS

Art.no.	Gap to floor (mm)	Height (mm)
<b>Blue (RAL 5005)</b>		
290-230-005	100	2300

#### Silver (RAL 9006)

690-225-005	50	2250
-------------	----	------

#### Yellow (RAL 1018)

190-230-005	100	2300
-------------	-----	------

#### Black (RAL 9011)

390-230-005	100	2300
-------------	-----	------

#### Light grey (RAL 9018)

490-230-005	100	2300
-------------	-----	------

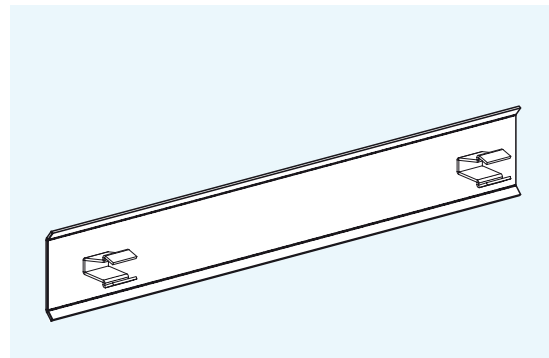

#### SHEET METAL STRIP

Art.no.	Length (mm)
<b>Light grey (RAL 9018)</b>	
411-000-025	250
411-000-040	400
411-000-070	700
411-000-100	1000



The panels and strips are also available in black (RAL 9011). In this case, the art. no. starts with 3.

# SHELFSTORE

## MESH SHELVING SYSTEM



① ShelfStore mesh shelving system with bent edge and 65x100 mm mesh spacing.

② The L-shaped front section ensures that the shelves sit securely in the rack and do not require bolting. This facilitates modification/ extension work.

**Axellent's ShelfStore** is a practical and very rigid mesh shelving system that is equally suitable for storing small items individually or for goods on pallets. Mesh shelves do not gather dust and will let through light and water, which is often a requirement if a sprinkler system is used.

depth of the shelf, allowing goods to be slid in and out easily. The L-shaped front section also ensures that the shelves sit securely in the rack and do not require bolting. This facilitates the work involved when modifying or extending your warehouse or stores. ShelfStore is available in a variety of different sizes, and is supplied wrapped on pallets.

All the parts for ShelfStore have been designed to make handling as safe and straightforward as possible. For example, the wires on the top of each shelf run the full

### MESH SHELVING SYSTEM

The following mesh shelves are stock items for delivery within a week in standard RAL 9018 finish.

H09470910	A=947 mm	B=910 mm	Load 250 kg/m <sup>2</sup> , typ K4, Constructor P90
H09970885	A=997 mm	B=885 mm	Load 250 kg/m <sup>2</sup> , typ K4, Constructor P90 "Silverline"
H09870910	A=987 mm	B=910 mm	Load 224 kg/m <sup>2</sup> , typ K4, EAB
H08951345	A=895 mm	B=1345 mm	Load 500 kg/m <sup>2</sup> , typ M6

A normal mesh spacing of 65x100 mm, ø 5 mm wires, RAL 7042 applies to these shelving systems.

HM091009004	A=910 mm	B=900 mm	Maximum load per shelf 1,000 kg.
HM091013204	A=910 mm	B=1320 mm	Maximum load per shelf 1,000 kg.
HM111009004	A=1110 mm	B=900 mm	Maximum load per shelf 1,000 kg.
HM110013205	A=1110 mm	B=1320 mm	Maximum load per shelf 1,000 kg.

### MAX. LOAD

Max. sag: 1/200 (0.5%),  
Safety class 3.

Max. sag in pallet rack horizontals:  
1/200 (0.5%),

Max. tolerance between horizontals:  
(A) +8 mm





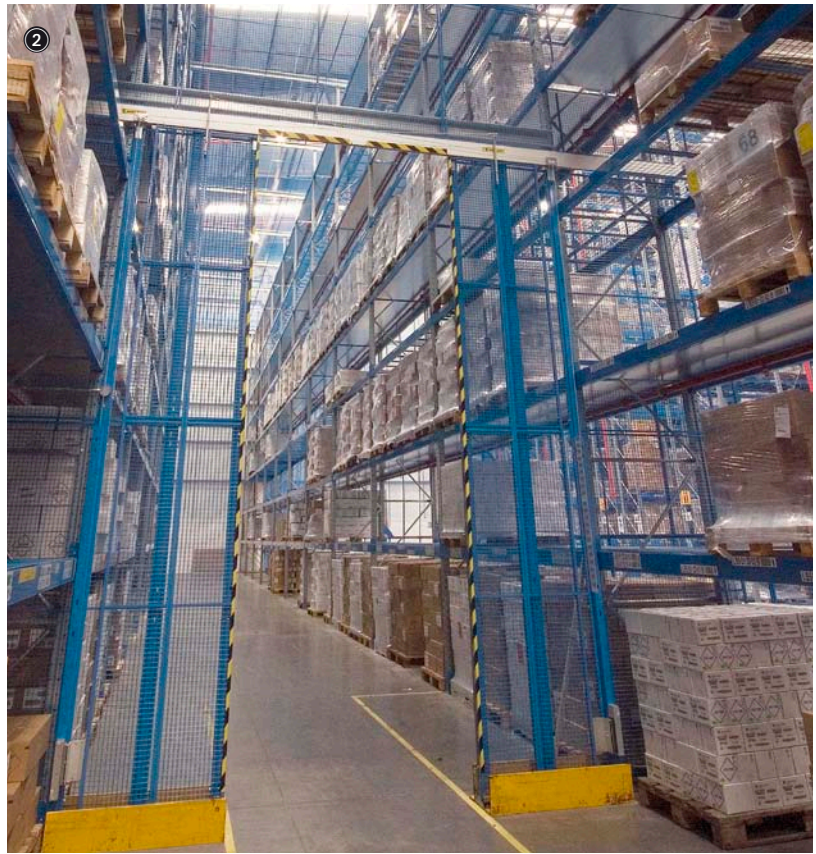

**SAFESTORE** ANTI-COLLAPSE PROTECTION SYSTEM/**FLEXISTORE** INDUSTRIAL AND WAREHOUSE WALLS  
**SHELFSTORE** MESH SHELVING SYSTEM

① Axelent SafeStore with 50x60 mesh spacing. Picture from Metalog, France.

② Axelent SafeStore as a anti-collapse protection system for a warehouse storing aerosol products. The protection system has sliding gates with a lock in the middle that allows the doors to remain open with a magnetic lock and automatically close with the aid of counterweights in the event of a fire.

③ Axelent FlexiStore, 3.35 m in height with 50x60 mesh spacing. Picture from Metalog, France.

④ ShelfStore in pallet shelving at IKEA's self-collection warehouse in Jönköping, Sweden.



# SAFETY STANDARDS

## EN STANDARDS

Following points are extracts from the EN SS-STANDARDS EN 953, EN 811 and EN 528

### SAFETY DISTANCES

EN 953 chapter 5.2.2

#### 1. Fixed guards

Machinery Directive 2006/42/EC annex 1 chapter 1.4.2.1  
Fixed guards must be fixed by systems that can be opened or removed only with tools.

Their fixing systems must remain attached to the guards or to the machinery when the guards are removed.

(Valid from 29/12/2009.) Where possible, guards must be incapable of remaining in place without their fixings.

#### 2. Safety Distances

EN 953 chapter 5.2.2

Guards intended for preventing access to danger zones shall be designed, constructed and positioned to prevent parts of the body from reaching danger zones (see also EN ISO 13857).

#### 3. Distances to impede free access

EN ISO 13857

A protective structure can be used to restrict the free movement of the lower limbs under protective structures. When this method has to be used, distances are given in annex A in relation to the height to the protective structure. Figure A1. (EN 811)

□ FIGURE A.1 (EN ISO 13857)

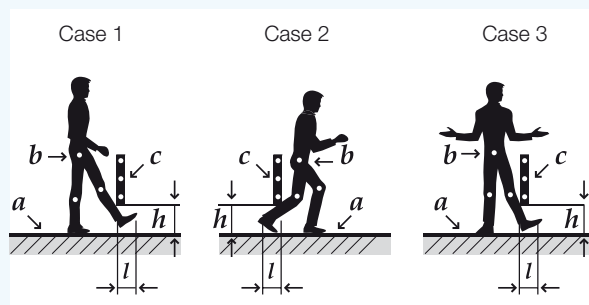

a - Reference plane  
b - Hip joint  
c - Protective structure

h - Height up to protective structure  
l - Distance for impedance

## SAFEGUARDING OF PERSONS (LIMITING ACCESS)

### 4. Enclosure, doors and/or removable panels

EN 528 Chapter 5.10.3.2

A perimeter enclosure in accordance with EN ISO 13857:2008, Table 1 and Table 4, but at least 2 m high.

Doors and/or removable panels in the perimeter enclosure:

a) Doors and/or removable panels shall be provided in the perimeter enclosure for access, operation, repair or maintenance.

b) Doors in the enclosure for the entrance and exit of people shall only open outwards and shall be constructed so that they can only be opened from the outside with a key, but can be opened from the inside without a key. The key for the doors shall be the same key or permanently connected to the key for the switches in 5.3.2 or 5.3.3.

(Axelent Note: For complete version of EN 528, please contact SIS +46 8 555 523 10, www.sis.se).

c) With a door in the perimeter enclosure open, movement of the machine in the corresponding machine operating area shall be prevented. Restarting can only take place on board the machine or from the control station outside the enclosure with the door closed (see 5.3.2 and 5.3.4).

(Axelent Note: For complete version of EN 528, please contact SIS +46 8 555 523 10, www.sis.se).

Unexpected start-up shall be prevented in accordance with EN 1037.

d) Access doors to the machine more than 1 m above ground level shall be locked so as to open only when the machine is in the correct position for access.

e) Removable panels that are frequently opened or can be opened without using tools shall be built and protected the same way as doors.

### 5. Means of separation within racking

EN 528 Chapter 5.10.3.3

A means of separation is required to deter access from one machine operating area into an adjacent machine operating area through the racking.

## LOAD ENTRY AND EXIT

### 6. Load transfer areas

EN 528 Chapter 5.10.4.1

These shall be arranged such that injury to persons due to the movement of the machine is prevented. This requirement for load transfer areas is fulfilled, if access at load entry/exit points is prevented, deterred, or the dangerous movements of the machines are stopped; examples, see Annex D.

## ESCAPE FROM DANGEROUS AREAS

### 7. Leaving of the aisle

EN 528 Chapter 5.10.6.1

It shall be possible to leave an aisle at both ends.

### 8. Leaving for emergency purposes

EN 528 Chapter 5.10.6.2

For emergency purposes and with the machine in its normal end position, a 0,5 m long and 2 m high clearance shall be provided at the ends of the aisles for access to the emergency exits (see Annex B, Figur B.2).



## 9. Clearances at additional equipment

EN 528 Chapter 5.10.6.3

Where additional equipment (e. g. conveyors) is installed at one end of an aisle, it may be acceptable to have reduced clearance where access between the equipment and the machine is normally required for maintenance only.

ANNEX B

**FIGURE B.2:** See bottom of this page

ANNEX D

### D.1 General

The following subclauses show the most used safety measures to prevent or deter the misuse of load entry/exit points to gain access to danger areas but do not exclude other measures.

### D.2 Measures against access between the conveyor and fixed guard

The area between the conveyor and the fixed guard (fencing) should be protected against access by e. g. sloping plates marked in warning colours (black/yellow – see Figure D.1). For distances of more than 0,5 m deterring nets or mats as described in D.4.4 should be provided.

**FIGURE D.1** — Sloping plates

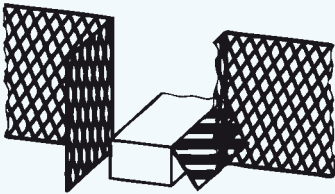

**FIGURE B.2:** Leaving for emergency purposes

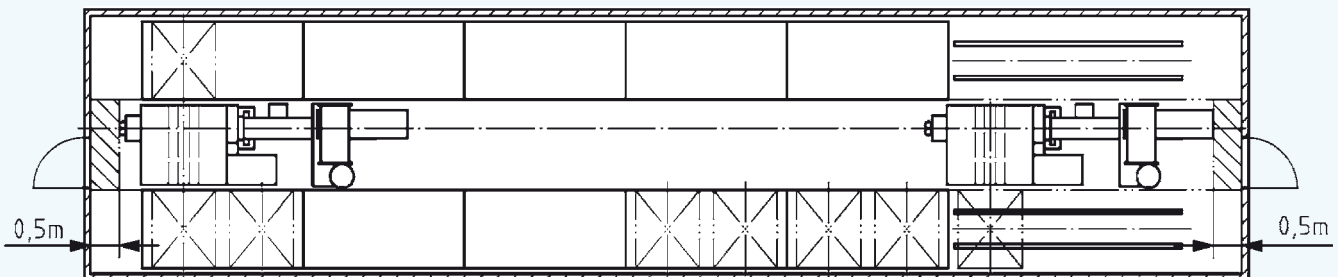

## D.5 MEASURES THAT PREVENT ACCESS

### D.5.1 General

If foreseeable misuse is possible, e. g. misbehaviour because of normal carelessness or because the way of the lowest resistance will be taken (e. g. conveyors) to get admittance to an dangerous area, it is not enough to deter the admittance, but it must prevented, as shown in the following example. The measures to be taken are to be fixed in a written risk analysis. In case of danger areas behind the safeguards in D.4.2 and D.4.3, safety distances in accordance with Table 1 of EN ISO 13857:2008, should be provided.

### D.5.2 Mechanical guards

Mechanical guards, e.g. swing gates, powered sliding doors, may be provided. The guard should only be released or opened to allow the passage of conveyed material.

**FIGURE D.6** — Mechanical guards

Key

- 1. gate
- 2. door

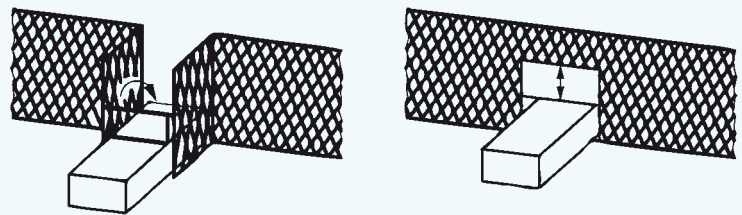

*NOTE Figures above just show the possible solutions for load exit. For load entry additional means to prevent crushing and shearing have to be added according to the general requirements (D.2).*

### D.6 Protecting devices

Protecting devices, in particular opto-electronic protecting devices (light guards) complying with EN 61496-1, may be provided. The installation has to be in accordance with EN 999, such that hazardous machinery will be stopped before it can be reached.



When ordering doors, specify whether the door is to be hung on the right (H) or left (V). Indicate this after the item number.



## AXELENT **STOREROOM** WALLS

Axelent storeroom walls are the ideal solution for secure, flexible and versatile storage in attics, cellars or other storage areas. The systems are easy to add to as they are based on standard components. The various components are always held in stock as well, ensuring rapid deliveries.



**Axelent STOREROOM F has robust tubular construction for the doors and can be supplied with a roof at heights above 3.2 metres.**

**Numbered plates are also available as accessories to Axelent's F storeroom walls. Specify the required number(s).**



# STOREROOM F

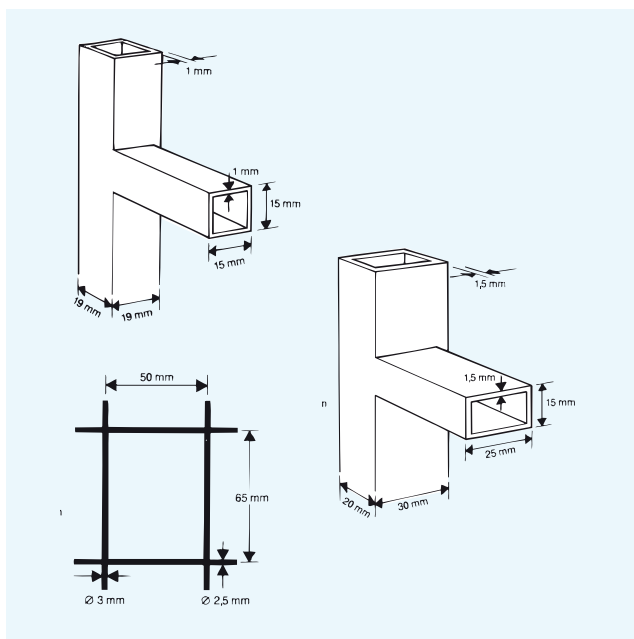

- With extra robust tubular construction in the doors.
- Can be cut and adapted to the existing building design.
- Can be supplied with a roof at heights above 3.2 metres.
- The doors are painted in RAL 9018.
- Numbered plates and wooden shelves are available as accessories.



**A specially adapted wooden shelf with a clothes rack is available as an accessory for Axelent's F storeroom walls. The shelf is secured to the walls using a bracket. Dimensions: 1200x400 mm. Item number: 30-6120**

PRODUCT FACTS	
Materials & design	Dimensions (mm)
Tubular steel frame, wall	
Vertical tubes,	19x19
Horizontal tubes	15x15
Tubular steel frame, door	
Vertical tubes	30x20
Horizontal tubes	25x15
Steel wire mesh	
Vertical wires	Ø 3,0
Horizontal wires	Ø 2,5
Mesh width	50x65
Opening measurements, door	
30-7075	1870x710
30-7090	1870x860

DIMENSIONS				
	Art.no.	Height (mm)	Width (mm)	
Wall section	30-2020	2250	200	
	30-2025	2250	250	
	30-2035	2250	350	
	30-2040	2250	400	
	30-2055	2250	550	
	30-2060	2250	600	
	30-2080	2250	800	
	30-2100	2250	1000	
	30-2110	2250	1100	
	30-2120	2250	1200	
	30-2130	2250	1300	
	30-2140	2250	1400	
	30-2150	2250	1500	
	Gauge block	30-2002	2250	20
	Door	30-7075	2250	750
30-7090		2250	900	

WWW.AXELENT.COM

Project: Creative Craft · Design: Mees · Print: XXXXXXXXXXXX · 05/2010

Axelent is a leading and growing company within mesh wall systems in the form of protection and partitioning systems for industry, warehouses and construction work. The Axelent Group also includes Axelent Wire Tray (cable ladders) and Axelent Safety (machine safety). Axelent's head office is in Hillerstorp, Sweden. All product development, production, warehousing and packaging also takes place here. Axelent has sales offices in 50 countries and its products are sold all over the world.



**AXELENT LTD**

Unit 9 Berkshire House  
County Park, Shrivenham Road  
Swindon SN1 2NR  
United Kingdom  
Axelent Direct: 01793 52 35 35  
Fax: 01793 43 24 24  
E-mail: [sales@axelent.com](mailto:sales@axelent.com)  
Internet: [www.axelent.com](http://www.axelent.com)